

Viper

- › VANDAL PROOF DOME CAMERA
- › DAY & NIGHT
- › INFRARED RANGE: 75 FEET
- › 3-AXIS MOUNT
- › METAL HOUSING
- › IP66 RATED



Model#: Viper

The Viper is a Vandalproof Infrared Dome Camera that will throw out infrared light up to 75' away. The Viper is a True Day/Night Camera with an automatic infrared cut filter that will ensure a sharp, clear image under normal lighting or even at night under infrared lighting. There is no focus shift like lesser infrared cameras.

The Viper has a 3-Axis mount that allows mounting in almost any position or configuration. The Viper has a 1/3" SONY Super HAD II Camera that delivers 580 lines of resolution, and a 4-9mm Varifocal Lens.

The Viper is IP66 Rated and can withstand water spray with no damage.

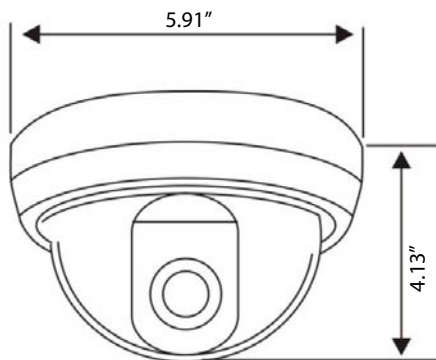

Image sensor	1/3" Sony Super HAD CCD II
Effective Pixels	NTSC : 768(H) x 494 (V)
Horizontal Resolution	NTSC : 580 TV Lines
Scanning system	2:1 Interlaced
Synchronizing system	Internal
Minimum Illumination	0Lux(LED ON)
Lens	Built-in 4 ~ 9mm Varifocal Lens
IR View Distance	About 75' with 36 LEDs
Back Light Compensation	Auto
White Balance	Auto
Gain Control	Auto
Electronic Shutter	NTSC : 1/60~1/100,000 sec.
S/N ratio	More than 50dB (AGC Off)
Gamma correction	>0.45
Video output	1.0 Vp-p Composite Signal (75ohm)
Operation Temperature	-10°C - +50°C
Operation Humidity	Within 95% RH
Power Supply	DC12V (+/-15%)
Dimensions (inches)	5.91"(L) X 5.91"(W) X 4.13"(H)
Weight-Net (Approx lbs.)	2.23lbs

Varifocal Lens Adjustment



Conduit Opening (If Needed)



Cable Routing Options

